

4:1 Scale view of double trolley system using CL-5 clamp. One double trolley each travel beam.

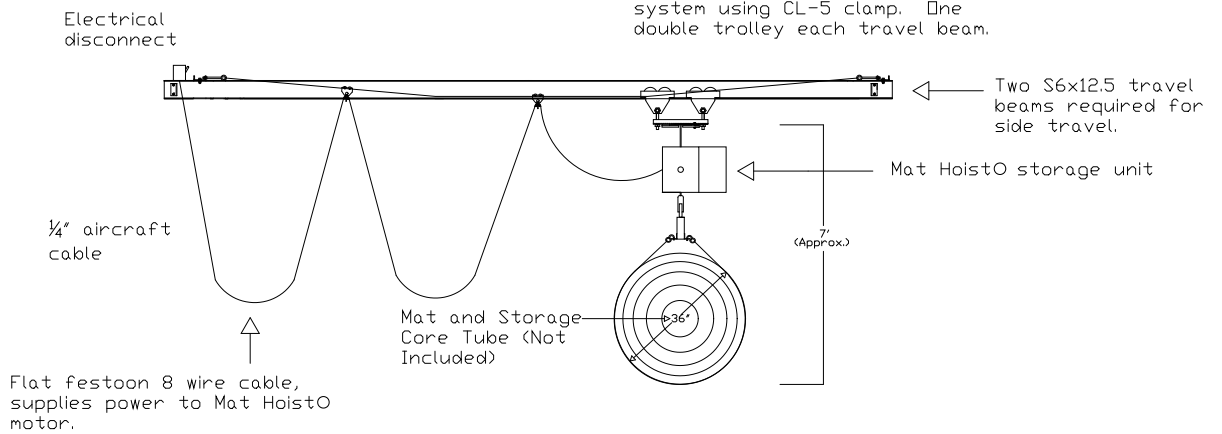

Note: Structural Strength of Truss & Wall NOT Responsibility of Mat HoistO Manufacturer.

NGE Inc.
P.O. Box 370/Industrial Park
302 North Erickson
Roland, IA 50236

Mat HoistO 2000
End View Side First Travel Unit
Drawing MH2000-07

Phone: (515)-388-4118
Fax: (515) 388-4340
Email: mathoist@mathoist.com
Website: www.mathoist.com